

▼ Cylinder Backset

Available in 31/32", 1-1/8" or 1-1/2".

▼ Case

Steel with corrosion-resistant plating. 1" x 7-3/8" x depth. (Depth varies by backset. See table on back page.)

▼ Latch Bolt

5/8" x 5/8" with 7/16" throw. Zinc alloy with Delrin face for smooth, quiet action. Handing easily reversible. Bolt can be held fully retracted to allow door to be free swinging. (See back page.)

▼ Function

Deadbolt Maximum Security after hours plus traffic control convenience for management during the business day. Typical installation is a bank or store requiring three modes of door control: 1. Both lock and latch bolts retracted for unrestricted entry and exit during business hours, 2. Handle-operated latch for exit-only traffic just after closing, and 3. Maximum Security hookbolt for overnight lockup. NOTE: Handle or paddle operates latchbolt only.

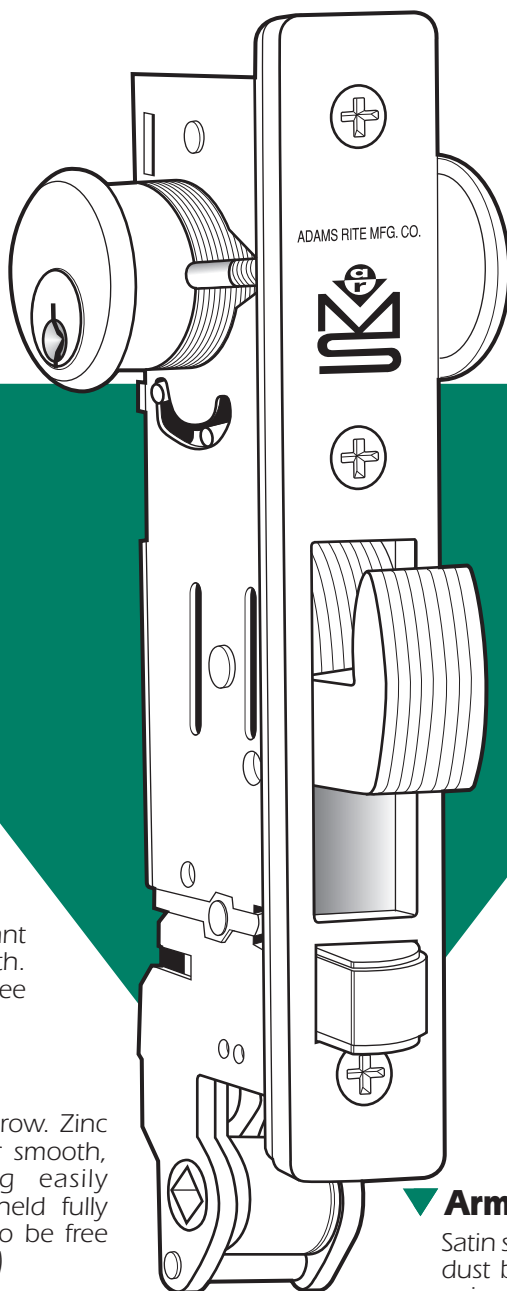

MS® Deadbolt/Latch

For Aluminum Stile Doors

MS+1890 Series

ANSI/BHMA Type E82101 (Grade 1)

**4505
Armored
Strike**

▼ Lock Bolt

5/8" x 1-3/8" with 13/16" throw. Eight ply laminated stainless steel. Center ply has Alumina-Ceramic core to defeat any hacksaw attack, including rod-type "super" hacksaws. Hook shape repels prybar attempts.

▼ Armored Strike

Satin stainless steel trim plate with steel mounting plate and dust box. Flat strike (shown) furnished. Also available for pairs of doors in radius shape, or flat with square corners for ANSI hollow metal jambs. Flat strikes also available with longer lip. (MS+1890 Deadbolt/Latch cannot be used with electric strikes.)

▼ Operation

360° turn of key or thumbturn throws or retracts the hook-shaped deadbolt. 120° further turn retracts latch bolt as well. Cylinder may be any make standard 1-5/32" diameter mortise type with MS® cam. Handle retracts spring-loaded latchbolt only.

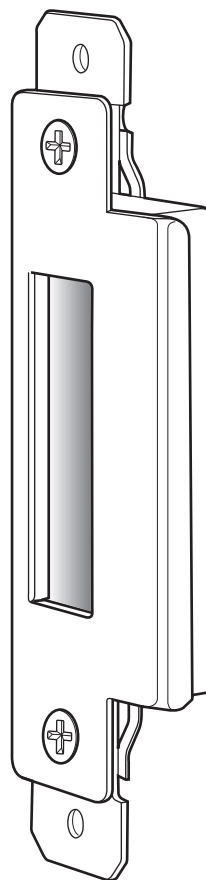



MS+1890 Deadbolt/Latch

DIMENSIONS

INCHES
MILLIMETERS

Nominal, subject to tolerance extremes.

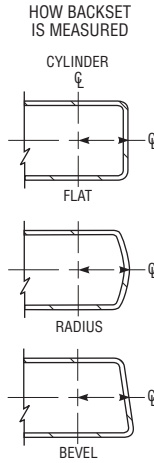
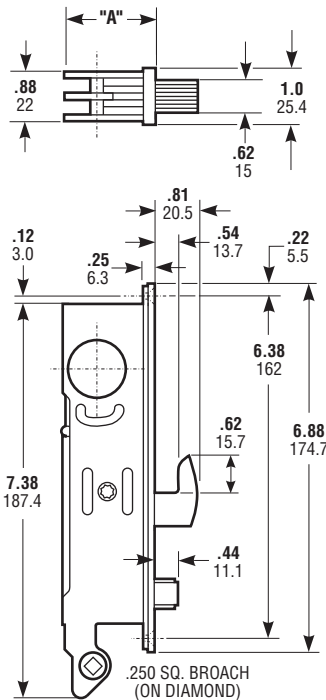

BACKSET	"A"
31/32" 24.6	1.63 41.4
1-1/8" 28.6	1.78 45.2
1-1/2" 38.1	2.25 57.1

ARMORED FACEPLATE 1" x 6-7/8"	
FLAT	MS+1890
RADIUS	MS+1891
RADIUS w/WEATHERSTRIP	MS+1891W
LH BEVEL	MS+1892(LH)
RH BEVEL	MS+1892(RH)

INSTALLATION

Cutout same as MS1850A Deadbolt plus holes for handle mount.

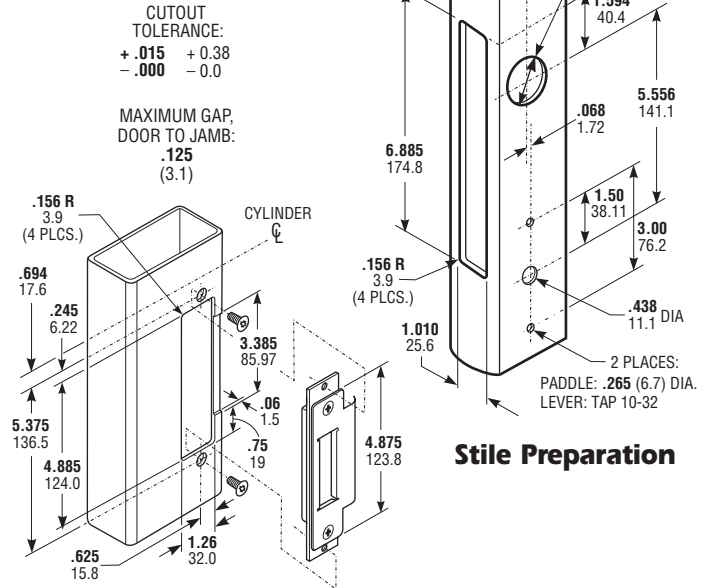

Stile Preparation

Jamb Preparation

(Covers any previous cutout for MS® Deadbolt)

Latch/Lock, Cylinder & Paddle Installation

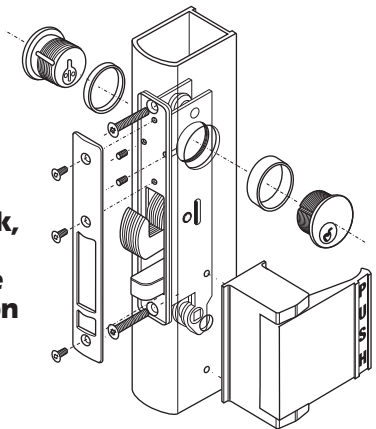

Cylinder Cam

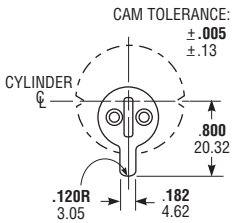

MS+1890 Series locks are operable by any standard 1-5/32" diameter mortise cylinder with special MS® cam dimensioned as shown. Cylinders with MS® cams can be readily obtained from most cylinder manufacturers. See page SW-33 for cylinder make and trim ring information.

HOW TO ORDER

Specify quantity and the following information.
Order handle and related hardware separately.

Faceplate Shape

- 1890** Flat
- 1891** Radius
- 1891W** Radius w/wStrip
- 1892** Bevel

Backset

- 2** 31/32"
- 3** 1-1/8"
- 4** 1-1/2"

Strike Shape/Lip Length

- 01** Flat/Standard Jamb
- 02** Radius/Standard Stile
- 17** Flat/Center-Hung 4.0" Jamb
- 21** Flat/Center-Hung 4.5" Jamb
- XX** Other Lip lengths

MS+1891-3026-628

Handing

- 5** LH or RHR
- 6** RH or LHR

Finish

- 628** Clear Anodized
- 313** Dark Bronze Anodized
- 335** Black Anodized

Order **HANDLE(s)** separately.

For door thickness other than 1-3/4", contact factory.

- 4568-11** Straight Lever
- 4569-11** Return End Lever
- 4591-11** Paddle, Pull to Left
- 4591-12** Paddle, Push to Left
- 4591-13** Paddle, Pull to Right
- 4591-14** Paddle, Push to Right

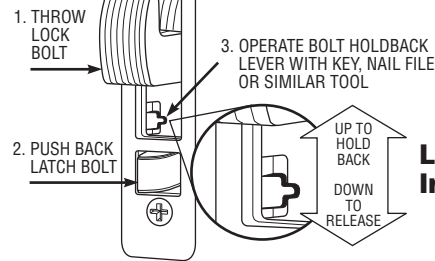

Latch Holdback Instructions

OPTIONS

Order handle/paddle for one side only or both sides. Handles/paddles on both sides solve, with minimum traffic impediment, the problem of doors that stand ajar due to wind.

STANDARD PACKAGE

Individually boxed with strike and machine screws for mounting. Cylinders available separately at extra cost. Shipping weight: 2 lbs.